

Operating Instruction



Universal power amplifier for proportional valves

Series EVM- ETC-2600...

Published by

Bucher Hydraulics AG Frutigen

Schwandstrasse 25

CH-3714 Frutigen

Phone +41 33 672 61 11

Email info.ch@bucherhydraulics.com

Internet www.bucherhydraulics.com

© 2024 by Bucher Hydraulics AG Frutigen, CH-3714 Frutigen

All rights reserved. This documentation, in whole and/or in part, is protected by copyright. It may not be reproduced, nor may it be stored, processed, replicated, or distributed by electronic means, without written permission from Bucher Hydraulics.

Data is provided for the purpose of product description only and must not be construed as warranted characteristics in the legal sense. No assertion regarding either a particular property or the fitness for a particular intended purpose can be derived or deduced from this information. The information does not relieve users from the duty of conducting their own evaluations and tests. Because the products are subject to continual improvement, we reserve the right to amend the product specifications contained in this catalogue. The original language and legal terminology of all Bucher Hydraulics documentation is exclusively German. Bucher Hydraulics cannot be held liable for any possible errors in translation.

CONTENTS

1	General Information	5
1.1	Order Number	5
1.2	Alternative products	5
1.3	Scope of supply	5
1.4	Accessories	5
1.5	Safety instructions.....	6
2	Characteristics	7
2.1	Features.....	7
2.2	Device description.....	8
3	Use and application	9
3.1	Installation instruction	9
3.2	Commissioning	10
4	Technical description	12
4.1	LED Indications.....	12
4.2	Typical system structure	13
4.2.1	Function "Directional" (1 proportional valve with 2 solenoids).....	13
4.2.2	Function "Independent" (2 independent proportional valves with 1 solenoid)	13
4.3	Input and output signals.....	14
4.4	Block diagram	15
4.5	Typical wiring	15
4.6	Technical data	16
5	EtherCAT IO interface.....	17
5.1	ETHERCAT CoE.....	17
5.2	EtherCAT installation	17
5.3	EtherCAT device profiles	18
5.3.1	Localization of the CoE on the EtherCAT Slave:.....	18
5.3.2	Device description file (ESI)	18
5.3.3	Object dictionary	19
5.3.4	SDO parameterization.....	19
5.3.5	Process data PDO	19
5.3.6	Object list	19
5.3.7	PDO mapping.....	20
5.4	EtherCAT System behavior, state machine of slave devices.....	20
5.4.1	Overview of the states.....	20
5.4.2	Possible transitions between the different states	20
5.4.3	Watchdog.....	21
5.4.4	Function channels	22
6	Parameter	23
6.1	CoE Parameter overview	23
6.1.1	Communication parameters	23
6.1.2	Rx PDO mapping	23
6.1.3	Tx PDO mapping.....	24
6.2	PDOs	26
6.2.1	Input Data.....	26
6.2.2	Output data	27
6.2.3	Parameters channel 0 (DIRECTIONAL).....	28
6.2.4	Parameters Channel 1 / 2 (INDEPENDENT)	31
6.2.5	Diagnosis messages.....	35
6.2.6	Module settings	36
6.2.7	Data types	37

7	Parameter descriptions.....	39
7.1	General functions.....	39
7.1.1	Data Storage.....	39
7.1.2	Loadback.....	39
7.1.3	Default.....	39
7.2	IO_BASE (Scaling of the input and output signals).....	39
7.2.1	SENS (Failure monitoring).....	40
7.2.2	FUNCTION (Choosing operation mode).....	40
7.2.3	RA (Ramp time).....	40
7.2.4	CCMODE (Activation of the linearization function).....	42
7.2.5	CC (Defining curve points).....	42
7.2.6	MMTYPE (Type of compensation).....	43
7.2.7	TRIGGER (Threshold).....	43
7.2.8	MIN (Deadband compensation).....	43
7.2.9	MAX (Output scaling).....	44
7.3	Parametrization of the power stage.....	44
7.3.1	CURRENT (nominal output current).....	44
7.3.2	DAMPL (Dither amplitude).....	44
7.3.3	DFREQ (Dither frequency).....	45
7.3.4	PWM (PWM frequency).....	45
7.3.5	ACC (Auto adaptation of the closed loop current controller).....	45
7.3.6	PPWM (Solenoid current controller P gain).....	46
7.3.7	IPWM (Solenoid current controller I gain).....	46
7.4	Process data (Monitoring).....	46
7.5	Parameterization with PS1.....	47
8	Appendix.....	48
8.1	Failure monitoring.....	48
8.2	Troubleshooting.....	48
9	History.....	49

1 General Information

1.1 Order Number

EVM-ETC-2600-2-30D-A1 Universal power amplifier with EtherCAT-interface for proportional valves

1.2 Alternative products

EVM-UIH-2600-2-30D-A1 Universal power amplifier for proportional valves

EVM-UIS-2600-2-30D-A1 Universal power amplifier with USB-interface for proportional valves

1.3 Scope of supply

The scope of supply includes the module plus the terminal blocks which are a part of the housing. Interface cables and further parts which may be required should be ordered separately.

This documentation can be downloaded as a PDF file from www.bucherhydraulics.com

1.4 Accessories

PS1 GUI for parametrization and monitoring of the power amplifier (free download from www.bucherhydraulics.com)

1.5 Safety instructions

Please read this document and the safety instructions carefully. This document will help to define the product area of application and to put it into operation. Additional documents and knowledge of the application should be considered or be available. General regulations and laws (depending on the country: e.g., accident prevention and environmental protection) must be complied with.



These modules are designed for hydraulic applications in open or closed loop control circuits. Uncontrolled movements can be caused by device defects (in the hydraulic module or the components), application errors and electrical faults. Work on the drive or the electronics must only be conducted whilst the equipment is switched off and not under pressure.



This handbook describes the functions and the electrical connections for this electronic assembly. All technical documents which pertain to the system must be complied with when commissioning.



This device may only be connected and put into operation by trained specialist staff. The instruction manual must be read with care. The installation instructions and the commissioning instructions must be followed. Guarantee and liability claims are invalid if the instructions are not complied with and/or in case of incorrect installation or inappropriate use.



All electronic modules are manufactured to a high quality. Malfunctions due to the failure of components cannot, however, be excluded. Despite extensive testing the same also applies for the software. If these devices are deployed in safety-relevant applications, suitable external measures must be taken to guarantee the necessary safety. The same applies for faults which affect safety. No liability can be assumed for damage.

Further instructions

The module may only be operated in compliance with the national EMC regulations. It is the user's responsibility to adhere to these regulations.



The device is only intended for use in the commercial sector.

When not in use the module must be protected from the effects of the weather, contamination, and mechanical damage.

The module may not be used in an explosive environment.

To ensure adequate cooling the ventilation slots must not be covered.

The device must be disposed of in accordance with national statutory provisions.

2 Characteristics

This module is used for controlling a directional valve with two solenoids or up to two pressure or throttle valves with one solenoid. Various adjustable parameters allow an optimal adaptation to the respective valve. This power amplifier is an inexpensive, robust, and space-saving solution.

The control signals are transmitted by an EtherCAT interface. Furthermore, it is possible to change the parameterization via this bus or via the USB interface. Two control modes are implemented, channel 0 for one directional valve or channel 1/2 for two independent pressure or throttle valves.

The output current is closed loop controlled and therefore independent from the power supply and the solenoid resistance. The output stage is monitored for cable breakdown and short circuit and disables the power stage in case of an error.

2.1 Features

- Control of directional, pressure or throttle valves
- Compact housing
- Digital reproducible adjustments
- Controlling via EtherCAT
- Simple and application orientated parameter settings
- Characteristics linearization via 10 XY-points per direction
- Free parameterization of RAMPS, MIN / MAX, PWM, output current and DITHER
- Rated output current up to 3.0 A
- Failure monitoring and extended function check

2.2 Device description

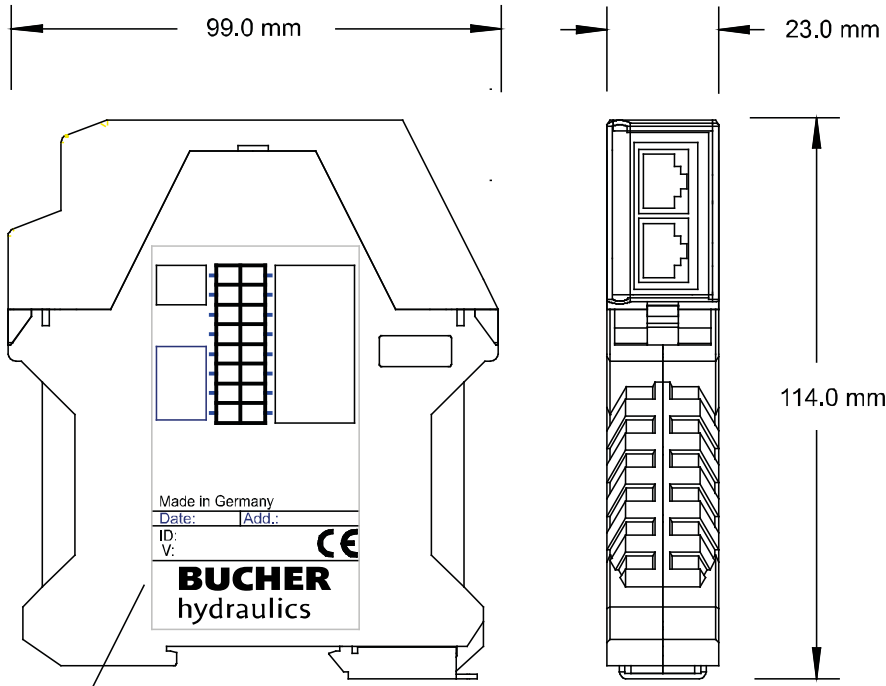

Typenschild und Anschlussbelegung
Type plate and terminal pin assignment

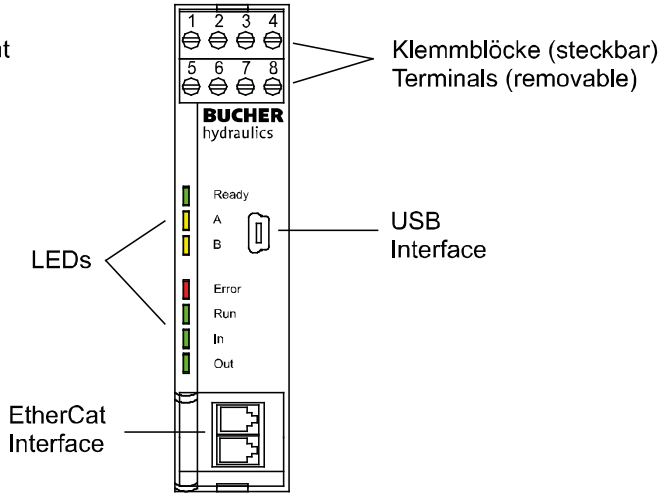

3 Use and application

3.1 Installation instruction

This module is designed for installation in a shielded EMC housing (control cabinet). All cables which lead outside must be screened; complete screening is required. It is also a requirement that no strong electro-magnetic interference sources are installed nearby when using our open and closed loop control modules.

The devices must be arranged in the control cabinet so that the power section and the signal section are separate from each other. Experience shows that the installation space close to the PLC (24 V area) is most suitable. All digital and analogue inputs and outputs are fitted with filters and surge protection in the device.



The module should be installed and wired in accordance with the documentation bearing in mind EMC principles. If other consumers are operated with the same power supply, a star-connected ground wiring scheme is recommended. The following points must be observed when wiring:



- The signal cables must be laid separately from power cables.
- Analogue signal cables must be screened.
- All other cables must be screened if there are powerful interference sources (frequency converters, power contactors) and cable lengths > 3m. Inexpensive SMD ferrites can be used with high-frequency radiation.
- The screening should be connected to PE (PE terminal) as close to the module as possible. The local requirements for screening must be considered in all cases. The screening should be connected to at both ends. Equipotential bonding must be provided where there are differences between the connected electrical components.
- With longer lengths of cable (>10 m) the diameters and screening measures should be checked by specialists (e.g., for interference, noise sources and voltage drop).

A low-resistance connection between PE and the mounting rail should be provided. Transient interference is transmitted from the module directly to the mounting rail and from there to the local earth.

Power should be supplied by a regulated power supply unit (typically a PELV system complying with IEC364-4-4, secure low voltage). The low internal resistance of regulated power supplies gives better interference voltage dissipation, which improves the signal quality of high-resolution sensors. Switched inductances (relays and valve coils connected to the same power supply) must always be provided with appropriate overvoltage protection directly at the coil.

3.2 Commissioning

Step	Task
Preparing of the communication	<p>The ESI file which is provided by Bucher must be supplied to the EtherCAT master. For that it must be copied into the relating directory of the programming software. Using TwinCat the path is located below <i>version/Config/IO</i> and EtherCAT. Next the fieldbus communication can be established. The procedure must be taken from the manual of the belonging master. The ESI file provides information about the available data objects.</p> <p>Alternatively, there is an USB interface on board for the usage with our PS1 software. This allows a start-up in case the PLC is not yet available currently.</p>
Switching on	<p>Install the device in accordance with the circuit diagram. Ensure it is wired correctly and that the signals are well shielded. The device must be installed in a protective housing (control cabinet or similar).</p> <p>Ensure that no unwanted movement of the drive is possible (e.g., switch off the hydraulics).</p> <p>Connect an amp meter and check the current consumed by the device. If it is higher than specified, there is an error in the wiring. Switch off the device immediately and check the wiring.</p>
Pre-parameterization	<p>Now set up the following parameters (with reference to the system design and circuit diagrams):</p> <p>The basic setup FUNCTION for configuring the inputs and outputs of the device. There are predefined PDOs available which should be selected accordingly.</p> <p>IO_BASE for defining the scaling of the signals.</p> <p>The nominal output CURRENT and the typical valve parameters such as PWM frequency, DITHER and MIN/MAX.</p>
	<p>A quick start guide about this topic can be found in chapter 7 (quick start configuration and parameterization).</p> <p>Pre-parameterization is necessary to minimize the risk of uncontrolled movements.</p>
Control signal	<p>Check the control signal with an amp meter. (The current of the solenoid is within the range of 0... 3.0A). In the actual state, it should show approximately 0 A.</p>
	<p>You also can monitor the current of the solenoids via the fieldbus or in the PS1 software.</p>
Switching on the hydraulics	<p>The hydraulics can now be switched on. The module is not yet generating a signal. Drives should be at a standstill or drift slightly (leave its position at a slow speed) if it is a proportional valve.</p>
Activating ENABLE	<p>The ENABLE bit/signal releases the application. If the system is error-free this will be indicated by the READY bit/signal.</p>

Step	Task
	The drive can now leave its position and move to an end position with full speed, or the pressure can reach maximum. Take safety measures to prevent personal injury and damage.
Giving demand value	The amplifier can now be controlled via the demand value.
Optimizing settings	Depending on the behavior of the system, the parameterization can now be improved and extended by ramp and linearization functions.
	The settings are not stored automatically. For keeping the parameterization permanently, the user must save it.

4 Technical description

4.1 LED Indications

LEDs	Indication	Description of the function
GREEN	<i>READY</i>	Display of the operational state of the amplifier: OFF: Power supply or ENABLE is not available ON: Operational state Flashing: Error detected
YELLOW YELLOW	<i>A</i> <i>B</i>	Activity of channel A: Activity of channel B: The intensity depends on the solenoid current.
RED	<i>FB-ERROR</i>	Error display of the fieldbus communication: OFF: No error Blinking: Invalid configuration Single flash: Unsolicited state change Double flash: Application watchdog timeout Flickering: Booting error ON: PDI watchdog timeout
GREEN	<i>FB-RUN</i>	Actual state of the fieldbus state machine: OFF: Initialization Blinking: Pre-operational Single flash: Safe-operational Flashing: Bootstrap ON: Operational
GREEN GREEN	<i>LINK-ACT-IN</i> <i>LINK-ACT-OUT</i>	Activity of the EtherCAT input: Activity of the EtherCAT output: OFF: No connection ON: Connection established Flashing: Communication is active

4.2 Typical system structure

The module can be set up for two different operating modes (for control of directional control valves = CHANNEL 0 or for two control of pressure / throttle valves = CHANNEL 1 and 2).

4.2.1 Function "Directional" (1 proportional valve with 2 solenoids)

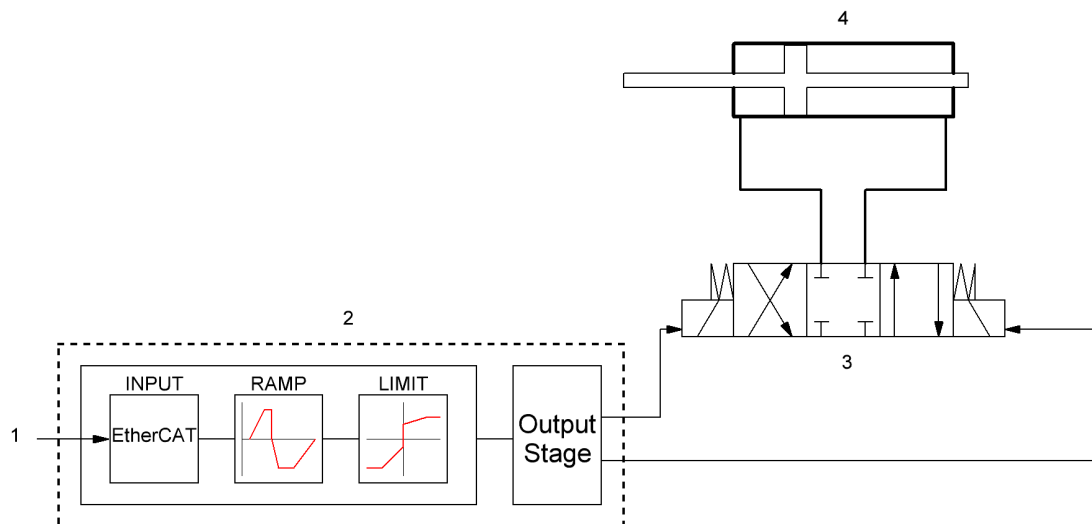

This system consists of the following components:

1. Interface to PLC with analog and digital signals
2. Power amplifier EVM-ETC-2600-2-30D-A1
3. Proportional valve
4. Hydraulic cylinder / actuator

4.2.2 Function "Independent" (2 independent proportional valves with 1 solenoid)

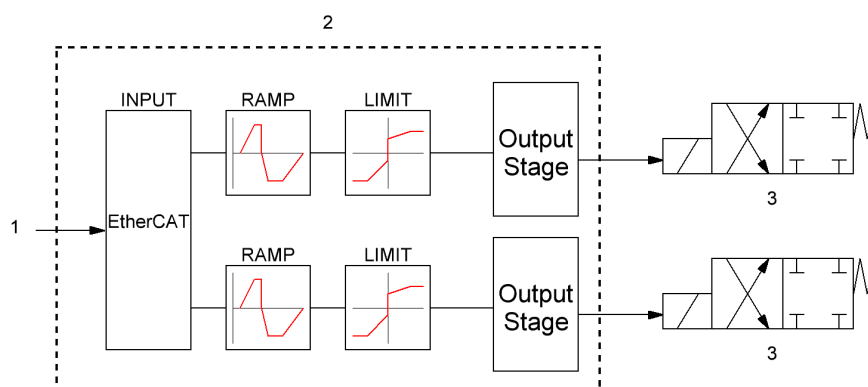

This system consists of the following components:

1. Interface to PLC with analog and digital signals
2. Power amplifier EVM-ETC-2600-2-30D-A1
3. Proportional valves

4.3 Input and output signals

Connection	Supply
PIN 7	Power supply (see technical data)
PIN 8	0 V (GND) Power supply.
Connection	PWM output
PIN 3 / 4	Current controlled PWM outputs for solenoid A (CH1). PIN 4 optionally can be common return in the directional mode (see circuit diagram).
PIN 2 / 1	Current controlled PWM outputs for solenoid B (CH2).

4.4 Block diagram

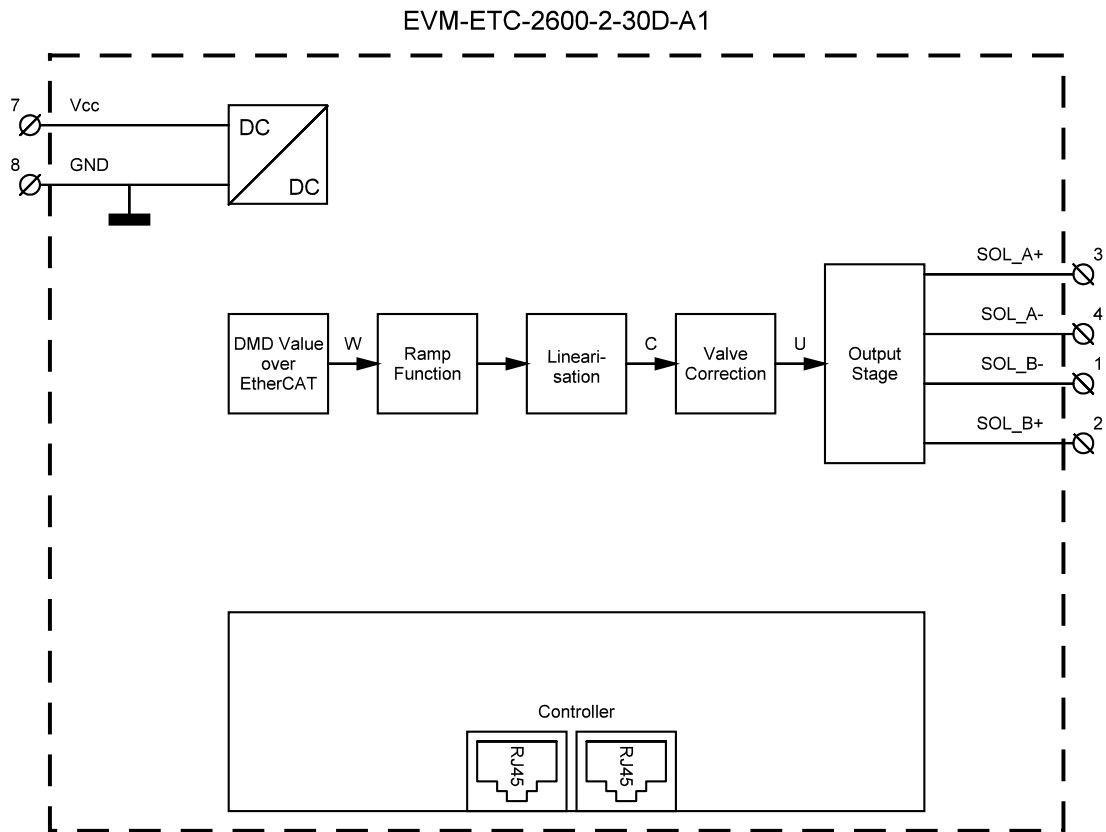

4.5 Typical wiring

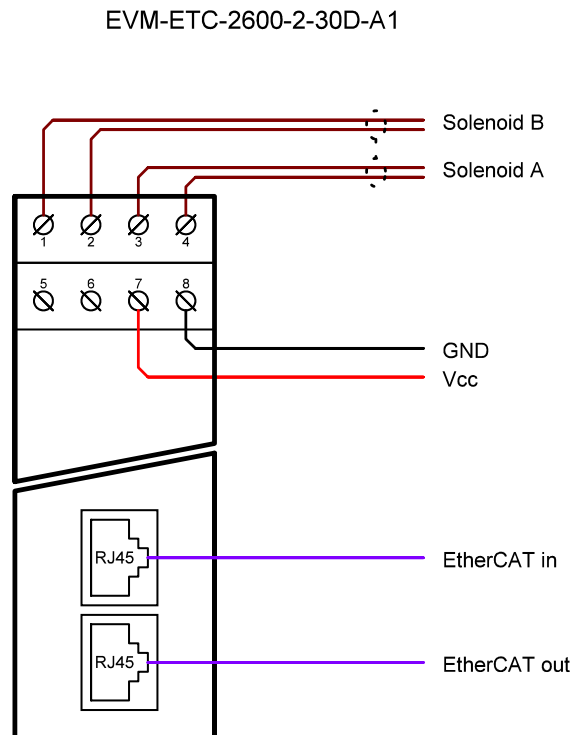

4.6 Technical data

Power supply (U _b)	[VDC]	12... 30 (incl. ripple)
Current consumption in idle mode	[mA]	60
Power consumption max.	[W]	80 (depending on type of solenoid, two solenoids are active)
External fuse	[A]	4 medium time lags
Digital inputs	[V]	< 2
OFF	[V]	> 10
ON	[kΩ]	25
Input resistance		
Digital outputs	[V]	< 2
OFF	[V]	max. U _b
ON	[mA]	50
Maximum current		
PWM output		broken wire monitored and short circuit proof
Max. output current	[mA]	0... 3000
PWM frequency	[Hz]	60...10000; adjustable in steps
Controller cycle times		
Internal signal processing	[ms]	1
solenoid current control	[μs]	53
EtherCAT	[Mbit/s]	100; relating to IEE 802.3
Serial interface		USB Virtual COM port driver 9600...115200 Baud 1 Stopbit, No parity, No handshake
Housing		Snap-On Module acc. EN 50022
Material		PA 6.6 polyamide
Color		Black
Flammybility class		V0 (UL94)
Weight	[g]	310
Protection class		IP20
Temperature range	[°C]	-20... 60
Storage temperature	[°C]	-20 ...70
Humidity	[%]	<95 (not condensing)
Vibration	-	IEC 60068-2-6 (category C)
Connections		USB type Mini 2 x RJ45 2 x 4pol. screw terminals PE: direct via DIN rail
EMC		EN 61000-6-2: 8/2005 EN 61000-6-4: 6/2007 ; A1:2011

5 EtherCAT IO interface

5.1 ETHERCAT CoE

EtherCAT is an Ethernet-based field bus system, developed by Beckhoff and the EtherCAT Technology Group (ETG). EtherCAT is an open technology standardized in the international standards IEC 61158 and IEC 61784 as well as in ISO 15745-4. EtherCAT can provide the same communication mechanisms as are known from CANopen: object directory, PDO (process data objects) and SDO (service data objects). Even network management is comparable. For example, EtherCAT can be implemented on devices that were previously equipped with CANopen with minimal effort; large parts of the CANopen firmware are reusable.

5.2 EtherCAT installation

EtherCAT supports almost any topology, line, tree, or star. The bus or line structure known from the fieldbuses thus also becomes available for Ethernet. Particularly useful for system wiring is the combination of lines and junctions or stubs. The required interfaces exist in the devices; no additional switches are required. Naturally, the classic switch-based Ethernet star topology can also be used.

The permissible cable length between two EtherCAT devices must not exceed 100 meters. This results from the Fast Ethernet technology, which for reasons of signal attenuation over the Line length allows a maximum link length of 5 + 90 + 5 m if lines with appropriate properties.

To connect EtherCAT devices, use only Ethernet (cable + plug) connections at least of category 5 (CAT5) according to EN 50173 or ISO / IEC 11801. EtherCAT uses four wires of the cable for signal transmission.

EtherCAT uses RJ45 connectors, for example. The contact assignment is compatible with the Ethernet standard (ISO / IEC 8802-3).

5.3 EtherCAT device profiles

For allocating the application-based index range of the EtherCAT, there are device profiles. Some are allocated within additional sub profiles. Thus, the EtherCAT automation protocol (1000), the EtherCAT device protocol (1100) and the AoE Router (9000) have their own sub profile numbers. Below these numbers the ports of devices which support the relating protocol have own object dictionaries. The device described in this document uses the *Modular device profile*, called MDP, defined in the specification 5001. It defines the range beginning with index 0x6000.

5.3.1 Localization of the CoE on the EtherCAT Slave:

The CoE directory as a parameter system must be administrated in the device in the firmware (FW) in the local controller. This is the so-called online directory, because it is only available for the user if the EtherCAT slave is in operation and, if applicable, can be manipulated via EtherCAT communication. So that the parameters can be viewed and changed in advance without the presence of a slave, a default copy of the entire directory is usually stored in the device description file ESI (XML). This is called the offline directory. Changes in this directory do not affect the later operation of the slave with the master.

The ESI description also defines the process image, the communication type between master and slave / device and the device functions, if applicable. The physical device (firmware, if available) must support the communication queries / settings of the master. This is backward compatible, i.e., newer devices (higher revision) should be supported if the EtherCAT master addresses them as an older revision.

The ranges in the Slave CoE that are important for the application oriented EtherCAT fieldbus user is:

0x1000:	This is where fixed identity information for the device is stored, including name, manufacturer serial number etc., plus information about the current and available process data configurations.
0x8000:	This is where the operational and functional parameters for all channels are stored, such as filter settings or output frequency. The following ranges are also of interest:
0x6000:	Input PDOs ("input" from the perspective of the EtherCAT master)
0x7000:	Output PDOs ("output" from the perspective of the EtherCAT master)
0xA000:	Diagnostic data
0xF000:	Area of the modular device (ETG 5001.1)

5.3.2 Device description file (ESI)

The 'ESI file (CoE directory) is provided by the manufacturer of an EtherCAT device. It is created in the description language XML and has a standardized format for the description of devices. The ESI file contains information about:

- Description of the file (name, version, creation date, etc.)
- General device information (manufacturer name and code)
- Device name and type, versions
- Description of the supported objects by their attributes

This file describes the available functions and data of the device via the EtherCAT fieldbus. For providing them to the user, this file is required by the master's engineering system. For that it must be put into the relating directory on the computer.

5.3.3 Object dictionary

Devices with CoE interface, like the one described here, have an object dictionary. This contains all data, which can be transmitted via the EtherCAT fieldbus, independent of the direction. The object dictionary is included in the device description file.

5.3.4 SDO parameterization

SDO is the shortcut for "service data object." Commonly those entries of the object dictionary are considered as SDOs which are located beginning with address 0x1000. They can be read out including its description by the SDO information service via the mailbox channel as soon as it is initialized. The description contains type, size, access rights and the PDO access.

The parameterization can be done via CoE. The application dependent parameters are located beginning with address 0x8000 or 0x8010/0x8020 depending on the channel.

5.3.5 Process data PDO

The input and output data of the EtherCAT slave are displayed as CANopen Process Data Objects (PDO).

The process data (PDOs) cyclically transmitted by an EtherCAT slave are the user data. They are expected or sent to the slave in the application. For this purpose, the EtherCAT Master (e.g., Beckhoff TwinCAT) parameterizes each EtherCAT slave during the start-up phase. It specifies the process data (size in bits / bytes, source location, transmission type) from or to the slave.

With so-called "intelligent" EtherCAT devices, the process data information is also available in the CoE directory. However, any changes in this CoE directory which lead to deviating PDO settings prevent the slave from booting successfully. It is not recommended to configure other than the intended process data, since the device firmware (if available) is tuned to these PDO combinations.

5.3.6 Object list

- Index object index PDO
- Subindex subindex PDO
- Name surname of PDO
- Flag RW read or write status of PDO
- Flag RO read only status; it is not possible to write data to the object
- Flag P an additional P characterizes the object as a process data object
- Value value of the object

5.3.7 PDO mapping

The PDO mapping determines which application objects out of the dictionary should be used as PDO. The user can change this mapping. This device provides some predefined mappings, which depend on the selected basic function of the amplifier.

5.4 EtherCAT System behavior, state machine of slave devices

5.4.1 Overview of the states

State	Description
INIT	Initializing state after switching on. Mailbox communication is getting prepared.
BOOT	Only mailbox communication via File-Access over EtherCAT is active. In this state a firmware update can be done.
PRE-OP	Mailbox communication has been checked and is active now. Process data communication and mapping are being prepared.
SAFE-OP	Mailbox and process data communication have been checked and are active. The EtherCAT-Slave Controller is actualized cyclically now, but the outputs of the device are still in safe state (Watchdog).
OP	Operational state. Output data can now be transmitted. The device forwards the received data from the master to the outputs now.

5.4.2 Possible transitions between the different states

State	Transition	Target state	Activity
INIT	IB IP	BOOT PRE-OP	Start mailbox communication for FoE protocol. Checking mailbox and starting the SDO-communication.
BOOT	BI	INIT	Stop mailbox communication.
PRE-OP	PI PS	INIT SAFE-OP	Stop SDO-communication. Start PDO-communication.
SAFE-OP	SI SP SO	INIT PRE-OP OP	Stop SDO- and PDO-communication. Stop PDO-communication. Start evaluating the master's demand.
OP	OI OP OS	INIT PRE-OP SAFE-OP	Stop SDO- and PDO-communication. Stop PDO-communication. Stop evaluating the master's demand.

5.4.3 Watchdog

Functionality

The watchdog is a monitoring function for the process data communication. If this gets disturbed, it sets the outputs to a safe state in a defined time. Normally this state is OFF, but it can vary in some devices depending on the settings.

There are two independent watchdogs provided:

SM (Sync Manager):	Monitoring of the process data communication of the device via EtherCAT.
PDI (Process Data Interface):	Monitoring of the process data communication to the local CPU of the device.

The response time is set separately for each function. A multiplier, valid for both functions, allows a wide range of adjustment. Putting in "0" also offers a deactivation of the watchdog. If the communication is disturbed, the outputs will not be set to a safe state in this case.

Adjustment

The settings can be found at the EtherCAT tab of the relating device (box) below extended settings / behavior. So, they are device specific and must be done for each individual device. The parameterization is taken over when starting the device if the marker in the belonging check box was set. Otherwise, the settings in the EtherCAT slave controller are not updated.

Function	Default	Range	Description
MULTIPLIER	2498	1... 65535	Setting watchdog basic time between 40 ns and ca 2.6 ms. Calculation: $1 / 25 \text{ MHz} * (\text{Multiplier} + 2)$.
PDI WATCHDOG	1000	0... 65535	Response time PDI monitoring 40 ns up to ca 172 s. Calculation: $t * \text{Multiplier}$. („0“ deactivates the monitoring.)
SM WATCHDOG	1000	0... 65535	Response time SM monitoring 40 ns up to ca 172 s. Calculation: $t * \text{Multiplier}$. („0“ deactivates the monitoring)

5.4.4 Function channels

This device provides two different basic functionalities which can be selected by the user. This leads to changing process data depending on the chosen functionality. Therefore, this amplifier is a so-called modular device which uses different channels for each function.

Channel 0

This is the channel for the directional mode. Here you can find all parameters and data of the whole device if a directional proportional valve with two solenoids should be controlled.

Channel 1/2

These channels are used for the independent mode. That means both outputs can be controlled independently from each other. So, there are two separate applications. The parameters and data contained here are only valid in the *independent* mode and for the relating output one.

6 Parameter

6.1 CoE Parameter overview

6.1.1 Communication parameters

Index	Group	Name	Data type	Flags	Default	Units	Comment
1000:00		DEVICE TYPE	UINT32	RO		-	
1001:00		ERROR REGISTER	UINT8	RO		-	
1008:00		DEVICE NAME		RO	EVM-ETC	-	
1009:00		HARDWARE VERSION		RO	10	-	
100A:00		SOFTWARE VERSION		RO	10	-	
1018:00	IDENTITY		UINT8	RO	0x04	-	Number of index entries.
1018:01		VENDOR ID	UINT32	RO	0x000005AE	-	
1018:02		PRODDUCT CODE	UINT32	RO	0x00C703F3	-	
1018:03		REVISION	UINT32	RO	0x00000007	-	Will eventually be increased
1018:04		SERIAL NUMBER	UINT32	RO	---	-	Not used

6.1.2 Rx PDO mapping

Index	Group	Name	Data type	Flags	Default	Units	Comment
1600:00	DIR		UINT8	RO	0x03 (3 _{dez})	-	Number of index entries.
1600:01		ENABLE		RO	0x70000101	-	General enabling of the device
1600:02						-	
1600:03		COMMAND VALUE		RO	0x70000320	-	Command value
1601:00	IND		UINT8	RO	0x06 (6 _{dez})	-	Number of index entries.
1601:01		ENABLE 1		RO	0x70100101	-	General enabling of channel 1
1601:02						-	
1601:03		COMMAND VALUE 1		RO	0x70100310	-	Command value for channel 1
1601:04		ENABLE 2		RO	0x70200101	-	General enabling of channel 2

Index	Group	Name	Data type	Flags	Default	Units	Comment
1601:05							
1601:06		COMMAND VALUE 2		RO	0x70200310	-	Command value for channel 2

6.1.3 Tx PDO mapping

Index	Group	Name	Data type	Flags	Default	Units	Comment
1A00:00	DIR_IN		UINT8	RO	0x0D (13 _{dez})	-	Number of index entries.
1A00:01		READY	UINT32	RO	0x60000101	-	Common readiness of the device
1A00:02							
1A00:03		MEMORY	UINT32	RO	0xA0000101	-	No Memory Error
1A00:04		UNDER-VOLTAGE	UINT32	RO	0xA0000201	-	supply voltage not too low
1A00:05		OVER VOLTAGE	UINT32	RO	0xA0000301	-	supply voltage not too high
1A00:06		OVER TEMPERATURE	UINT32	RO	0xA0000401	-	Controller temperature not too high
1A00:07							
1A00:08		SHORT SOLENOID A	UINT32	RO	0xA0100101	-	No short circuit at solenoid A
1A00:09		OPEN SOLENOID A	UINT32	RO	0xA0100201	-	No open circuit at solenoid A
1A00:0A							
1A00:0B		SHORT SOLENOID B	UINT32	RO	0xA0200101	-	No short circuit at solenoid B
1A00:0C		OPEN SOLENOID B	UINT32	RO	0xA0200201	-	No open circuit at solenoid B
1A00:0D							
1A01:00	IND_IN		UINT8	RO	0x03 (3 _{dez})	-	Number of index entries.
1A01:01		READY 1	UINT32	RO	0x60100101	-	
1A01:02							Common readiness of channel 1
1A01:03		READY 2	UINT32	RO	0x60200101	-	Common readiness of channel 2
1A01:04							

Index	Group	Name	Data type	Flags	Default	Units	Comment
1A01:05		MEMORY	UINT32	RO	0xA0000101	-	No memory (internal) error
1A01:06		UNDER-VOLTAGE	UINT32	RO	0xA0000201	-	Supply voltage not too low
1A01:07		OVER VOLTAGE	UINT32	RO	0xA0000301	-	Supply voltage not too high
1A01:08		OVER TEMPERATURE	UINT32	RO	0xA0000401	-	Controller temperature not too high
1A01:09							
1A01:0A		SHORT SOLENOID A	UINT32	RO	0xA0100101	-	No short circuit at solenoid A
1A01:0B		OPEN SOLENOID A	UINT32	RO	0xA0100201	-	No open circuit at solenoid A
1A01:0C							
1A01:0D		SHORT SOLENOID B	UINT32	RO	0xA0200101	-	No short circuit at solenoid B
1A01:0E		OPEN SOLENOID B	UINT32	RO	0xA0200201	-	No open circuit at solenoid B
1A01:0F							
1A02:00	DIR_SIG		UINT8	RO	0x05 (5 _{dez})	-	Number of index entries.
1A02:01		W	UINT32	RO	0x60000310	-	Actual command value
1A02:02		C	UINT32	RO	0x60000410	-	Control signal after CC
1A02:03		U	UINT32	RO	0x60000510	-	Output signal
1A02:04		IA	UINT32	RO	0x60000610	-	Current at solenoid A
1A02:05		IB	UINT32	RO	0x60000710	-	Current at solenoid B
1A03:00	IND_SIG		UINT8	RO	0x06 (6 _{dez})	-	Number of index entries.
1A03:01		W1	UINT32	RO	0x60100310	-	Actual command value channel 1
1A03:02		C1	UINT32	RO	0x60100410	-	Control signal after CC channel 1
1A03:03		U1	UINT32	RO	0x60100510	-	Output signal channel 1
1A03:04		I1	UINT32	RO	0x60100610	-	Solenoid current at channel 1
1A03:05		W2	UINT32	RO	0x60200310	-	Actual command value channel 2
1A03:06		C2	UINT32	RO	0x60200410	-	Control signal after CC channel 2

Index	Group	Name	Data type	Flags	Default	Units	Comment
1A03:07		U2	UINT32	RO	0x60200510	-	Output signal channel 2
1A03:08		I2	UINT32	RO	0x60200610	-	Solenoid current at channel 2

6.2 PDOs

6.2.1 Input Data

Index	Group	Name	Data type	Flags	Default	Units	Comment
6000:00	DIR		UINT8	RO	0x07 (7 _{dez})	-	Number of index entries.
6000:01		READY	BOOL	RO	-	-	Common readiness of the device
6000:02							
6000:03		W	INT	RO	-	-	Actual command value
6000:04		C	INT	RO	-	-	Control signal after CC
6000:05		U	INT	RO	-	-	Output signal
6000:06		IA	UINT	RO	-	mA	Current at solenoid A
6000:07		IB	UINT	RO	-	mA	Current at solenoid B
6010:00	IND1		UINT8	RO	0x06 (6 _{dez})	-	Number of index entries.
6010:01		READY1	BOOL	RO	-	-	Common readiness of channel 1
6010:02							
6010:03		W1	UINT	RO	-	-	Actual command value channel 1
6010:04		C1	UINT	RO	-	-	Control signal after CC channel 1
6010:05		U1	UINT	RO	-	-	Output signal channel 1
6010:06		I1	UINT	RO	-	mA	Solenoid current at channel 1
6020:00	IND2		UINT8	RO	0x06 (6 _{dez})	-	Number of index entries.
6020:01		READY2	BOOL	RO	-	-	Common readiness of channel 2
6020:02							
6020:03		W2	UINT	RO	-	-	Actual command value channel 2

Index	Group	Name	Data type	Flags	Default	Units	Comment
6020:04		C2	UINT	RO	-	-	Control signal after CC channel 2
6020:05		U2	UINT	RO	-	-	Output signal channel 2
6020:06		I2	UINT	RO	-	mA	Solenoid current at channel 2

6.2.2 Output data

Index	Group	Name	Data type	Flags	Default	Units	Comment
7000:00	DIR		UINT8	RO	0x03 (3 _{dez})	-	Number of index entries.
7000:01		ENABLE	BOOL	RW	-	-	General enabling of the device
7000:02							
7000:03		COMMAND VALUE	DINT	RW	-	-	Command value
7010:00	IND1		UINT8	RO	0x03 (3 _{dez})	-	Number of index entries.
7010:01		ENABLE1	BOOL	RW	-	-	General enabling of channel 1
7010:02							
7010:03		COMMAND VALUE 1	UINT	RW	-	-	Command value of channel 1
7020:00	IND2		UINT8	RO	0x03 (3 _{dez})	-	Number of index entries.
7020:01		ENABLE2	BOOL	RW	-	-	General enabling of channel 2
7020:02							
7020:03		COMMAND VALUE 2	UINT	RW	-	-	Command value of channel 2

6.2.3 Parameters channel 0 (DIRECTIONAL)

Index	Group	Name	Data type	Flags	Default	Units	Comment
8002:00	RAMP		UINT8	RO	0x05 (5 _{dez})	-	Number of index entries.
8002:01							
8002:02		RA:UP:A	UDINT	RW	100	ms	Ramp time increasing solenoid current A
8002:03		RA:DOWN:A	UDINT	RW	100	ms	Ramp time decreasing solenoid current A
8002:04		RA:UP:B	UDINT	RW	100	ms	Ramp time increasing solenoid current B
8002:05		RA:DOWN:B	UDINT	RW	100	ms	Ramp time decreasing solenoid current B
8006:00	CC		UNIT8	RO	0x2A (42 _{dez})	-	Number of index entries.
8006:01		CCB:10_X	INT	RW	-10000	0,01%	X-coordinate point -10
8006:02		CCB:10_Y	INT	RW	-10000	0,01 %	Y coordinate point -10
8006:03		CCB:9_X	INT	RW	-9000	0,01 %	X coordinate point -9
8006:04		CCB:9_Y	INT	RW	-9000	0,01 %	Y coordinate point -9
8006:05		CCB:8_X	INT	RW	-8000	0,01 %	X coordinate point -8
8006:06		CCB:8_Y	INT	RW	-8000	0,01 %	Y coordinate point -8
8006:07		CCB:7_X	INT	RW	-7000	0,01 %	X coordinate point -7
8006:08		CCB:7_Y	INT	RW	-7000	0,01 %	Y coordinate point -7
8006:09		CCB:6_X	INT	RW	-6000	0,01 %	X coordinate point -6
8006:0A		CCB:6_Y	INT	RW	-6000	0,01 %	Y coordinate point -6
8006:0B		CCB:5_X	INT	RW	-5000	0,01 %	X coordinate point -5
8006:0C		CCB:5_Y	INT	RW	-5000	0,01 %	Y coordinate point -5
8006:0D		CCB:4_X	INT	RW	-4000	0,01 %	X coordinate point -4
8006:0E		CCB:4_Y	INT	RW	-4000	0,01 %	Y coordinate point -4
8006:0F		CCB:3_X	INT	RW	-3000	0,01 %	X coordinate point -3
8006:10		CCB:3_Y	INT	RW	-3000	0,01 %	Y coordinate point -3

Index	Group	Name	Data type	Flags	Default	Units	Comment
8006:11		CCB:2_X	INT	RW	-2000	0,01 %	X coordinate point -2
8006:12		CCB:2_Y	INT	RW	-2000	0,01 %	Y coordinate point -2
8006:13		CCB:1_X	INT	RW	-1000	0,01 %	X coordinate point -1
8006:14		CCB:1_Y	INT	RW	-1000	0,01 %	Y coordinate point -1
8006:15		CCA:0_X	INT	RW	0	0,01 %	X coordinate point 0
8006:16		CCA:0_Y	INT	RW	0	0,01 %	Y coordinate point 0
8006:17		CCA:1_X	INT	RW	1000	0,01 %	X coordinate point 1
8006:18		CCA:1_Y	INT	RW	1000	0,01 %	Y coordinate point 1
8006:19		CCA:2_X	INT	RW	2000	0,01 %	X coordinate point 2
8006:1A		CCA:2_Y	INT	RW	2000	0,01 %	Y coordinate point 2
8006:1B		CCA:3_X	INT	RW	3000	0,01 %	X coordinate point 3
8006:1C		CCA:3_Y	INT	RW	3000	0,01 %	Y coordinate point 3
8006:1D		CCA:4_X	INT	RW	4000	0,01 %	X coordinate point 4
8006:1E		CCA:4_Y	INT	RW	4000	0,01 %	Y coordinate point 4
8006:1F		CCA:5_X	INT	RW	5000	0,01 %	X coordinate point 5
8006:20		CCA:5_Y	INT	RW	5000	0,01 %	Y coordinate point 5
8006:21		CCA:6_X	INT	RW	6000	0,01 %	X coordinate point 6
8006:22		CCA:6_Y	INT	RW	6000	0,01 %	Y coordinate point 6
8006:23		CCA:7_X	INT	RW	7000	0,01 %	X coordinate point 7
8006:24		CCA:7_Y	INT	RW	7000	0,01 %	Y coordinate point 7
8006:25		CCA:8_X	INT	RW	8000	0,01 %	X coordinate point 8
8006:26		CCA:8_Y	INT	RW	8000	0,01 %	Y coordinate point 8
8006:27		CCA:9_X	INT	RW	9000	0,01 %	X coordinate point 9
8006:28		CCA:9_Y	INT	RW	9000	0,01 %	Y coordinate point 9
8006:29		CCA:10_X	INT	RW	10000	0,01 %	X coordinate point 10
8006:2A		CCA:10_Y	INT	RW	10000	0,01 %	X coordinate point 10

Index	Group	Name	Data type	Flags	Default	Units	Comment
800A:00	MINMAX		UINT8	RO	0x09 (9 _{dez})	-	Number of index entries.
800A:01		CCMODE	DT0802EN03	RW	0FF	-	Activation of the linearization function
800A:02							
800A:03		MMTYPE	DT0805EN03	RW	JMP	-	Compensation type: jump or linear
800A:04							
800A:05		TRIGGER	UINT	RW	200	0,01 %	Threshold of the compensation value
800A:06		MIN:A	UINT	RW	0	0,01 %	Deadband compensation value solenoid A
800A:07		MAX:A	UINT	RW	10000	0,01 %	Output scaling solenoid A
800A:08		MIN:B	UINT	RW	0	0,01 %	Deadband compensation value solenoid B
800A:09		MAX:B	UINT	RW	10000	0,01 %	Output scaling solenoid B
800D:00	POWER STAGE		UINT8	RO	0x0A (10 _{dez})	-	Number of index entries.
800D:01							Reserved
800D:02		CURRENT	UINT	RW	1000	mA	Nominal solenoid current
800D:03		DAMPL	UINT	RW	500	0,01 %	Dither amplitude
800D:04		DFREQ	UINT	RW	120	Hz	Dither frequency
800D:05		PWM	DT0803EN05	RW	2604	Hz	PWM frequency
800D:06							
800D:07		ACC	DT0802EN03	RW	ON	-	Automatic solenoid current controller adjustment
800D:08							
800D:09		PPWM	UINT	RW	7	-	P gain solenoid current controller
800D:0A		IPWM	UINT	RW	40	-	I gain solenoid current controller

6.2.4 Parameters Channel 1 / 2 (INDEPENDENT)

Index	Group	Name	Data type	Flags	Default	Units	Comment
8012:00	RAMP CH 1		UINT8	RO	0x03 (3 _{dez})	-	Number of index entries.
8012:01							
8012:02		RA:UP:1	UDINT	RW	100	ms	Ramp time increasing solenoid current
8012:03		RA:DOWN:1	UDINT	RW	100	ms	Ramp time decreasing solenoid current
8022:00	RAMP CH 2		UINT8	RO	0x03 (3 _{dez})	-	Number of index entries.
8022:01							
8022:02		RA:UP:2	UDINT	RW	100	ms	Ramp time increasing solenoid current
8022:03		RA:DOWN:2	UDINT	RW	100	ms	Ramp time decreasing solenoid current
8016:00	CC CH 1		UNIT8	RO	0x16(22 _{dez})	-	Number of index entries Channel 1
8016:01		CC1:0_X	INT	RW	0	0,01 %	X coordinate point 0
8016:02		CC1:0_Y	INT	RW	0	0,01 %	Y coordinate point 0
8016:03		CC1:1_X	INT	RW	1000	0,01 %	X coordinate point 1
8016:04		CC1:1_Y	INT	RW	1000	0,01 %	Y coordinate point 1
8016:05		CC1:2_X	INT	RW	2000	0,01 %	X coordinate point 2
8016:06		CC1:2_Y	INT	RW	2000	0,01 %	Y coordinate point 2
8016:07		CC1:3_X	INT	RW	3000	0,01 %	X coordinate point 3
8016:08		CC1:3_Y	INT	RW	3000	0,01 %	Y coordinate point 3
8016:09		CC1:4_X	INT	RW	4000	0,01 %	X coordinate point 4
8016:0A		CC1:4_Y	INT	RW	4000	0,01 %	Y coordinate point 4
8016:0B		CC1:5_X	INT	RW	5000	0,01 %	X coordinate point 5
8016:0C		CC1:5_Y	INT	RW	5000	0,01 %	Y coordinate point 5

Index	Group	Name	Data type	Flags	Default	Units	Comment
8016:0D		CC1:6_X	INT	RW	6000	0,01 %	X coordinate point 6
8016:0E		CC1:6_Y	INT	RW	6000	0,01 %	Y coordinate point 6
8016:0F		CC1:7_X	INT	RW	7000	0,01 %	X coordinate point 7
8016:10		CC1:7_Y	INT	RW	7000	0,01 %	Y coordinate point 7
8016:11		CC1:8_X	INT	RW	8000	0,01 %	X coordinate point 8
8016:12		CC1:8_Y	INT	RW	8000	0,01 %	Y coordinate point 8
8016:13		CC1:9_X	INT	RW	9000	0,01 %	X coordinate point 9
8016:14		CC1:9_Y	INT	RW	9000	0,01 %	Y coordinate point 9
8016:15		CC1:10_X	INT	RW	10000	0,01 %	X coordinate point 10
8016:16		CC1:10_Y	INT	RW	10000	0,01 %	X coordinate point 10
8026:00	CC CH 2		UNIT8	RO	0x16 (22 _{dez})	-	Number of index entries Channel 2
8026:01		CC2:0_X	INT	RW	0	0,01 %	X coordinate point 0
8026:02		CC2:0_Y	INT	RW	0	0,01 %	Y coordinate point 0
8026:03		CC2:1_X	INT	RW	1000	0,01 %	X coordinate point 1
8026:04		CC2:1_Y	INT	RW	1000	0,01 %	Y coordinate point 1
8026:05		CC2:2_X	INT	RW	2000	0,01 %	X coordinate point 2
8026:06		CC2:2_Y	INT	RW	2000	0,01 %	Y coordinate point 2
8026:07		CC2:3_X	INT	RW	3000	0,01 %	X coordinate point 3
8026:08		CC2:3_Y	INT	RW	3000	0,01 %	Y coordinate point 3
8026:09		CC2:4_X	INT	RW	4000	0,01 %	X coordinate point 4
8026:0A		CC2:4_Y	INT	RW	4000	0,01 %	Y coordinate point 4
8026:0B		CC2:5_X	INT	RW	5000	0,01 %	X coordinate point 5
8026:0C		CC2:5_Y	INT	RW	5000	0,01 %	Y coordinate point 5
8026:0D		CC2:6_X	INT	RW	6000	0,01 %	X coordinate point 6
8026:0E		CC2:6_Y	INT	RW	6000	0,01 %	Y coordinate point 6
8026:0F		CC2:7_X	INT	RW	7000	0,01 %	X coordinate point 7
8026:10		CC2:7_Y	INT	RW	7000	0,01 %	Y coordinate point 7

Index	Group	Name	Data type	Flags	Default	Units	Comment
8026:11		CC2:8_X	INT	RW	8000	0,01 %	X coordinate point 8
8026:12		CC2:8_Y	INT	RW	8000	0,01 %	Y coordinate point 8
8026:13		CC2:9_X	INT	RW	9000	0,01 %	X coordinate point 9
8026:14		CC2:9_Y	INT	RW	9000	0,01 %	Y coordinate point 9
8026:15		CC2:10_X	INT	RW	10000	0,01 %	X coordinate point 10
8026:16		CC2:10_Y	INT	RW	10000	0,01 %	X coordinate point 10
801A:00	MINMAX CH 1		UINT8	RO	0x07 (7 _{dez})	-	Number of index entries Channel 1.
801A:01		CCMODE:1	DT0802EN03	RW	OFF	-	Activation of the linearization function
801A:02							
801A:03		MMTYPE:1	UINT	RW	JMP	-	Compensation type: jump or linear
801A:04							
801A:05		TRIGGER:1	UINT	RW	200 _{dez}	0,01 %	Threshold of the compensation value
801A:06		MIN:1	UINT	RW	0 _{dez}	0,01 %	Deadband compensation value solenoid 1
801A:07		MAX:1	UINT	RW	10000 _{dez}	0,01 %	Output scaling solenoid 1
802A:00	MINMAX CH 2		UINT8	RO	0x07 (7 _{dez})	-	Number of index entries Channel 2.
802A:01		CCMODE:2	DT0802EN03	RW	OFF	-	Activation of the linearization function
802A:02							
802A:03		MMTYPE:2	UINT	RW	JMP	-	Compensation type: jump or linear
802A:04							
802A:05		TRIGGER:2	UINT	RW	200 _{dez}	0,01 %	Threshold of the compensation value
802A:06		MIN:2	UINT	RW	0 _{dez}	0,01 %	Deadband compensation value solenoid 2

Index	Group	Name	Data type	Flags	Default	Units	Comment
802A:07		MAX:2	UINT	RW	10000 _{dez}	0,01 %	Output scaling solenoid 2
Power stage							
80xD:00	POWER STAGE CH 1		UINT8	RO	0x0A (10 _{dez})	-	Number of index entries.
801D:01							
801D:02		CURRENT:1	UINT	RW	1000	mA	Nominal solenoid current
801D:03		DAMPL:1	UINT	RW	500	0,01 %	Dither amplitude
801D:04		DFREQ:1	UINT	RW	120	Hz	Dither frequency
801D:05		PWM:1	DT0803EN05	RW	2604	Hz	PWM frequency
801D:06							
801D:07		ACC:1	DT0802EN03	RW	ON	-	Automatic solenoid current controller adjustment
801D:08							
801D:09		PPWM:1	UINT	RW	7	-	P gain solenoid current controller
801D:0A		IPWM:1	UINT	RW	40	-	I gain solenoid current controller
802D:00	POWER STAGE CH 2		UINT8	RO	0x0A (10 _{dez})	-	Number of index entries.
802D:01							
802D:02		CURRENT:2	UINT	RW	1000	mA	Nominal solenoid current
802D:03		DAMPL:2	UINT	RW	500	0,01 %	Dither amplitude
802D:04		DFREQ:2	UINT	RW	120	Hz	Dither frequency
802D:05		PWM:2	DT0803EN05	RW	2604	Hz	PWM frequency
802D:06							
802D:07		ACC:2	DT0802EN03	RW	ON	-	Automatic solenoid current controller adjustment
802D:08							

Index	Group	Name	Data type	Flags	Default	Units	Comment
802D:09		PPWM:2	UINT	RW	7	-	P gain solenoid current controller
802D:0A		IPWM:2	UINT	RW	40	-	I gain solenoid current controller

6.2.5 Diagnosis messages

Index	Group	Name	Data type	Flags	Default	Units	Comment
A000:00	DIAG		UINT8	RO	0x04 (4 _{dez})	-	Number of index entries.
A000:01		MEMORY	BOOL	RO	-	-	Operational readiness of the device
A000:02		UNDERVOLTAGES	BOOL	RO	-	-	Supply voltage is too low
A000:03		OVERVOLTAGES	BOOL	RO	-	-	Supply voltage is too high
A000:04		TEMPERATURE	BOOL	RO	-	-	Overtemperature
A010:00	DIAG 1		UINT8	RO	0x02 (2 _{dez})	-	Number of index entries.
A010:01		SHORT CIRCUIT	BOOL	RO	-	-	Short circuit at output 1 (magnet A)
A010:02		OPEN CIRCUIT	BOOL		-	-	Cable break at output 1 (magnet A)
A020:00	DIAG 2		UINT8	RO	0x02 (2 _{dez})	-	Number of index entries.
A020:01		SHORT CIRCUIT	BOOL	RO	-	-	Short circuit at output 2 (magnet B)
A020:02		OPEN CIRCUIT	BOOL		-	-	Cable break at output 2 (magnet B)

6.2.6 Module settings

Index	Group	Name	Data type	Flags	Default	Units	Comment
F800:00	BASIS		UNIT8	RO	0x03 (3 _{dez})	-	Number of index entries.
F800:01		IO_BASE	UINT	RW	10000	-	Value base for command values, feedback values and parameter settings
F800:02		FUNCTION	DT0800EN03	RW	DIR	-	Module function: IND for two independent channels (Channel 1 und 2) or DIR for one channel (Channel 0) for directional valves with two solenoids.
F800:03		SENS	DT0801EN03	RW	ON	-	
F801:00	FUNC		UNIT8	RO	0x04 (4 _{dez})	-	Number of index entries.
F801:01		PASSWORD		WO		-	
F801:02		SAVE		WO		-	Setting this parameter to „1“ will save all parameters in the internal EEPROM. This is acknowledged by the device by momentarily setting the return value to 0x11111111.
F801:03		DEFAULT		WO		-	Setting this parameter to „1“ will restore the standard settings in the RAM. This is acknowledged by the device by momentarily setting the return values to 0x11111111.
F801:04		LOADBACK		WO		-	Setting this parameter to „1“ will restore all parameter values that have been saved previously in the EEPROM. This is acknowledged by the device by momentarily setting the return values to 0x11111111.
F80F:00	MANU				0x02 (2 _{dez})		Number of index entries.

Index	Group	Name	Data type	Flags	Default	Units	Comment
F80F:01			UINT	RW		-	Reserved
F80F:02			UINT	RW		-	Reserved

6.2.7 Data types

Index	Group	Name	Data type	Flags	Default	Units	Comment
0800:01		DIRECTIONAL	DT0800EN03	RO	1	-	Switching to the operating mode of the module
800:02		INDEPENDENT	DT0800EN03	RO	2	-	
0801:01		OFF	DT0801EN03	RO	1	-	Control function SENS
0801:02		ON	DT0801EN03	RO	2	-	
0801:03		AUTO	DT0801EN03	RO	3	-	
0802:01		OFF	DT0802EN03	RO	0	-	Binary Parameters
0802:02		ON	DT0802EN03	RO	1	-	
0803:01		60	DT0803EN05	RO	0x11		Frequency table, value in 1/s
0803:02		70	DT0803EN05	RO	0x0e		
0803:03		80	DT0803EN05	RO	0x0b		
0803:04		100	DT0803EN05	RO	0x08		
0803:05		120	DT0803EN05	RO	0x05		
0803:06		150	DT0803EN05	RO	0x02		
0803:07		200	DT0803EN05	RO	0x13		
0803:08		250	DT0803EN05	RO	0x10		
0803:09		400	DT0803EN05	RO	0x0d		
0803:0A		500	DT0803EN05	RO	0x0a		
0803:0B		600	DT0803EN05	RO	0x07		
0803:0C		800	DT0803EN05	RO	0x04		
0803:0D		1000	DT0803EN05	RO	0x01		

Index	Group	Name	Data type	Flags	Default	Units	Comment
0803:0E		1200	DT0803EN05	RO	0x12		
0803:0F		1500	DT0803EN05	RO	0x0f		
0803:10		2000	DT0803EN05	RO	0x0c		
0803:11		2500	DT0803EN05	RO	0x09		
0803:12		3000	DT0803EN05	RO	0x06		
0803:13		6000	DT0803EN05	RO	0x03		
0803:14		10000	DT0803EN05	RO	0x14		
0804:01		LIN	DT0804EN03	RO	0		
0804:02		SIN	DT0804EN03	RO	1		
0805:01		JMP	DT0805EN03	RO	0		Coverage compensation
0805:02		LIN	DT0805EN03	RO	1		

7 Parameter description

7.1 General functions

7.1.1 Data Storage

To parameterize the device for the required functionality the settings described in chapter 7 must be made.

Using EtherCAT there are three ways to accomplish this:

- Usage of the EtherCAT master engineering system and setting of the relevant SDO in the online view of the slave. After all needed entries have been made, a transfer of these settings is performed by using F801:01 (*Function Parameters/Save Parameters*). So, the parameters are stored permanently.
- Defining of tasks which will be automatically performed by the EtherCAT master during start-up. For this e.g., TwinCAT offers a tab "Startup" on the properties – mask of the slave device. There the needed parameters must be set one after another. By this data is stored permanently in the master instead of the slave.
- There is also the possibility to write parameter values by system functions of the master PLC. This method is the most elaborate, but it offers the possibility to change parameters during the operation by the PLC program. It is also possible to combine this method with the others. Attention: The "Save" command triggers write access to the internal EEPROM and therefore must not be called cyclically.

7.1.2 Loadback

Via this command (PS1 or EtherCAT) the last saved data will be restored.

7.1.3 Default

Via this command (PS1 or EtherCAT) the default parameters are reactivated.

7.2 IO_BASE (Scaling of the input and output signals)

The reference value for 100% command and feedback values can be defined here. So, it can be adapted to the used number system. E.g., a value of 10000 can be chosen to use 0.01% units or 16383 to use 3FFF as maximum.

Adjustable range: 100... 32767

7.2.1 SENS (Failure monitoring)

This command is used to activate / deactivate the monitoring functions (output current and internal failures) of the module.

ON	All monitoring functions are active. Detected failures can be reset by deactivating the ENABLE input.
OFF	No monitoring function is active.
AUTO	Auto reset mode. All monitoring functions are active. If the failure does not exist anymore, the module resumes to work automatically.



Normally the monitoring functions are always active because otherwise no errors are detectable via the READY output. The possibility of deactivation is provided especially for troubleshooting.



AUTO MODE: The module checks each second the actual failure status, which will (in case of a persistent error) trigger the LED and the READY output for a short time.

7.2.2 FUNCTION (Choosing operation mode)

This parameter allows adapting the amplifier to valves with one solenoid (IND, e.g., pressure valves) or to such with two solenoids (DIR, directional valves). The relating parameters for the directional mode are listed in channel 0. The channels 1 and 2 contain the parameters for the two separate channels in independent mode. This is the main basic adjustment of the device which should be done at first.

7.2.3 RA (Ramp time)

This amplifier provides a ramp function for the demand values. There are two-time values for increasing demand and decreasing demand for each solenoid.

Adjustable range: 1... 120000 Milliseconds

When using the independent mode, the two channels are separated and so the ramp functions are independent, too.

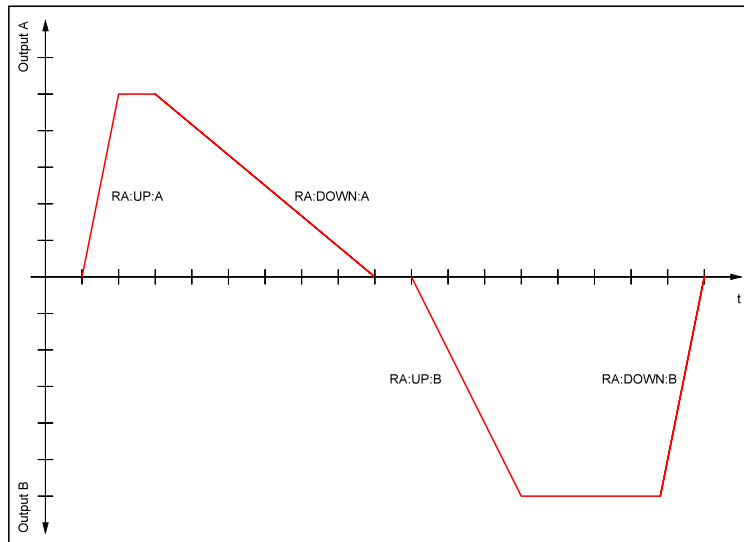

In the directional mode, this ramp function is a four-quadrant-ramp. If the direction of control is altered (change of sign of the command value), first the deceleration ramp of the old direction is completed (RA:DOWN:A/B) before the acceleration in the new direction starts (RA:UP:A/B).

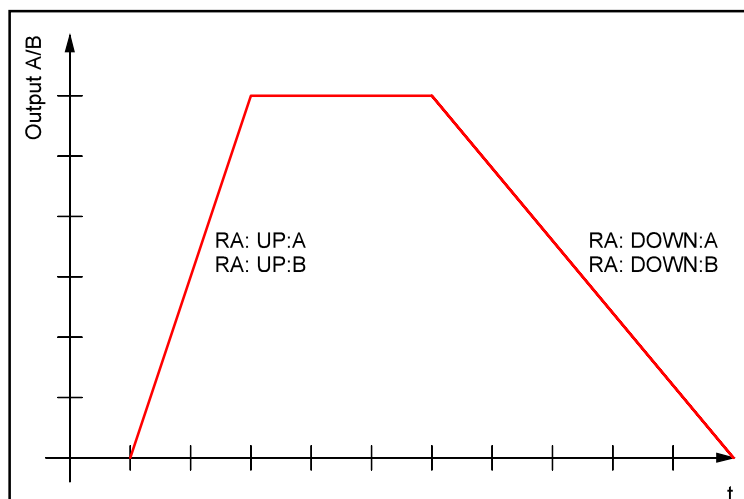

7.2.4 CCMODE (Activation of the linearization function)

This command is used for activating and deactivating the linearization function. By immediately deactivating the linearization an easy and fast evaluation of the linearization is possible.

- ON Linearization function CC is active (nevertheless, the default setting of the curve points will cause no effect on the output)
- OFF Linearization function CC is not active.



When using the CC command, the parameters MIN, MAX, and TRIGGER must be considered. Those commands influence each other and so using both can complicate evaluating the result.

7.2.5 CC (Defining curve points)

A user defined signal characteristic can be set by this function. For activating the parameter CCMODE must be switched ON first.

The curve is calculated according to the equation of a linear interpolation

$$y = \frac{(x - x_1) * (y_1 - y_0)}{(x_1 - x_0)} + y_1$$

The influence of the linearization can be estimated via the process data.

For each solenoid there are 10 points to define the curve. Those are determined by a X-value and a Y value. The input signal of the function is displayed by the X axis and the relating output value on the Y axis.

Adjustable range: 0... 10000(IND) respectively -10000... 10000(DIR)

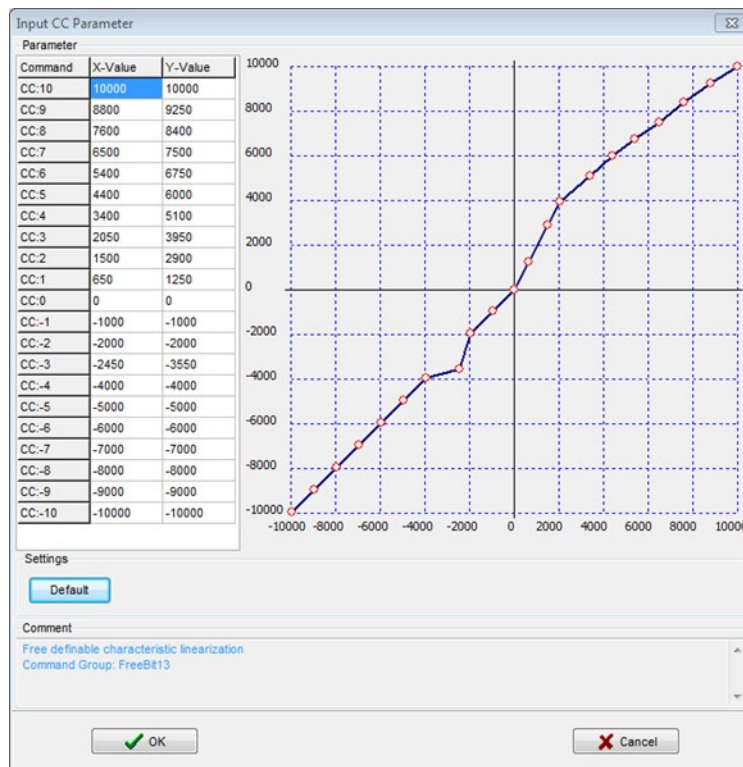

7.2.6 MMTYPE (Type of compensation)

The overlap of a valve can be compensated in different ways. One solution is a jump of the output signal to the compensation value when reaching an activation threshold (JMP). Alternatively, the output current can be increased linearly to the compensation value at the activation threshold (LIN).

This setting can be recommended if the driven valve is part of a control loop.

7.2.7 TRIGGER (Threshold)

The TRIGGER defines when the MIN value is activated. A non-sensitive range around the zero-point can be accomplished. This dead band is necessary, to avoid unrequested activations caused by small variations of the input signal. If this module is used in a position controls, the TRIGGER value should be reduced (typical: 1...10).

Adjustable range: 0... 3000

7.2.8 MIN (Deadband compensation)

With the MIN value the overlap (deadband) of the valve is compensated. If the control signal passes the trigger point, this value is the minimum starting value of the output.

Adjustable range: 0... 6000



When setting the compensation value too high, small movements or speeds are no more possible.

7.2.9 MAX (Output scaling)

With the MAX value the output signal (the maximum current) can be adapted if necessary.

Adjustable range: 5000... 10000

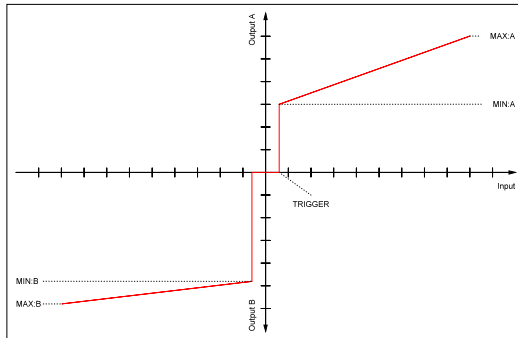

Fig.1: mode DIR, directional valve with 2 solenoids

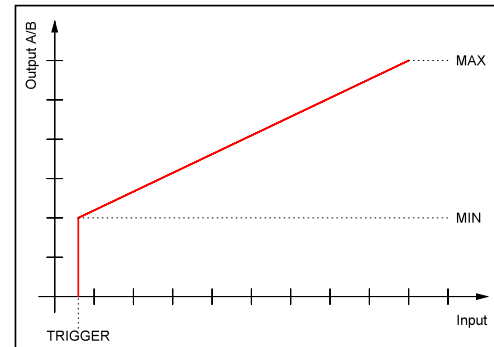

Fig.2: mode IND, one solenoid each channel

7.3 Parametrization of the power stage

7.3.1 CURRENT (nominal output current)

This parameter defines the nominal current of the solenoid. Dither amplitude and MIN/MAX settings always refer to this value.

Adjustable range: 500... 3000

7.3.2 DAMPL (Dither amplitude)

Setting the amplitude of the dither signal referring to the nominal current.

Adjustable range: 0... 3000



If the PWM frequency is less than 500 Hz, the dither amplitude should be set to zero.

7.3.3 DFREQ (Dither frequency)

Choosing the frequency of the dither signal.

Adjustable range: 60... 400



The PPWM and IPWM parameters influence the effect of the dither setting. These parameters should not be changed again after the dither has been optimized.



If there are no adjustment data from the valve manufacturer, proceed as follows: First, the amplitude is adjusted based on the hysteresis of the valve. Then setting starts with a low dither frequency. The user should increase it step by step. The aim is that no oscillation (often observed as humming of the valve) is noticeable at the end of the tuning procedure.

Alternatively, the PWM frequency can also be used as a dither. In this case, the dither amplitude must be set to zero and a low PWM frequency is set (typically: 60 ... 250 Hz). Again, no humming on the drive should be detectable after the adjustment.

7.3.4 PWM (PWM frequency)

The frequency can be changed in the defined steps. The best working frequency depends on the valve.

Selectable values: 60 / 70 / 80 / 100 / 120 / 150 / 200 / 250 / 400 / 500 / 600 / 800 / 1000 / 1200 / 1500 / 2000 / 2500 / 3000 / 6000 / 10000



The PPWM and IPWM parameters should be adapted when using low PWM frequencies because of the longer dead times which forces a reduced stability of the closed loop control.



With ACC = ON, the parameters of the PI current controller are automatically changed depending on the PWM frequency.

7.3.5 ACC (Auto adaptation of the closed loop current controller)

This parameter activates or deactivates the automatic adjustment of the solenoid current controller.

- | | |
|-----|--|
| ON | PPWM and IPWM are adapted depending on the pre-set PWM-frequency. The parameters PPWM and IPWM cannot be altered by the user in this case. |
| OFF | Manual adjustment of PPWM and IPWM, no automatic adaptation is done. |

7.3.6 PPWM (Solenoid current controller P gain)

This command is used to parameterize the P component of the current controller for the magnets.

Adjustable range: 0... 300



These parameters should not be changed without adequate measurement facilities and experiences. If the parameter ACC is set to ON, these adjustments are done automatically.

7.3.7 IPWM (Solenoid current controller I gain)

This command is used to parameterize the I component of the current controller for the magnets.

Adjustable range: 0... 100



These parameters should not be changed without adequate measurement facilities and experiences. If the parameter ACC is set to ON, these adjustments are done automatically.

7.4 Process data (Monitoring)

The process data are the variable values which can be continuously observed by using PS1.

Command	Description	Unit	Function
W	Command value after input scaling	%	DIR
C	Command value after ramp function	%	
U	Command value to current controller	%	
IA	Output current of solenoid A	mA	
IB	Output current of solenoid B	mA	
W1	Command value after input scaling channel 1	%	IND
C1	Command value after ramp function channel 1	%	
U1	Command value to current controller channel 1	%	
I1	Solenoid current channel 1	mA	
W2	Command value after input scaling channel 2	%	
C2	Command value after ramp function channel 2	%	
U2	Command value to current controller channel 2	%	
I2	Solenoid current channel 2	mA	

7.5 Parameterization with PS1

This device can alternatively be connected to PS1.

The advantages are the structured display of parameters and therefore a better user guidance. Furthermore, characteristic curves are displayed graphically thus enabling a plausibility check.

The groups can be switched by the parameter "Mode." The sequence System -> IO_CONFIG -> CONTROL can be recommended.

In the group System first the function (DIR/IND) is chosen.

As a result, in the other groups only the parameters are displayed which belong to the chosen function.

If only a simple parameterization of the basic functionality is intended the parameter "USER" should remain in the STD setting, meaning standard view. Then extended functions like the curve input or the tuning of the solenoid current controller are not displayed.

After the parameter entry using PS1 a manual "SAVE" command is required, initiated by the button beside the parameter table.

An operation completely without EtherCAT is possible in "Remote Control" mode (see monitor window). This can be interesting for functional tests without PLC.

8 Appendix

8.1 Failure monitoring

Following error sources are monitored continuously when SENS = ON / AUTO:

Source	Fault	Characteristics
Solenoid A PIN 3 / 4 Solenoid B PIN 1 / 2	Broken wire	The power stage is deactivated.
Solenoid A PIN 3 / 4 Solenoid B PIN 1 / 2	Short circuit	The power stage is deactivated.
EEPROM (Monitored during power on procedure)	Data error	The power stage is deactivated. The module can only be activated by saving the parameters.
EtherCAT communication	Interrupt	The power stage is deactivated.

8.2 Troubleshooting

With the flashing READY LED and the deactivated READY signal an occurred error will be reported by the module. Possible errors are for example:

- Broken wire or wrong wiring of the solenoids
- Internal data error. For restarting, please execute command SAVE for starting with DEFAULT values.

Possible errors can be read out via the fieldbus (see Tx PDOs) or the monitor of the PS1 program. Additionally, there are some status messages and warnings provided for evaluating the situation.

9 History

Revision	Date	Short mark	Comment
00	22.01.2024	LK / MAK	Initial version